

# PreciCONTROL

Application: COP, SPDS, DTMQ, MID, FTL



Alfons Haar

## Automation in tank truck construction: Minimizes costs, weight, installation and maintenance

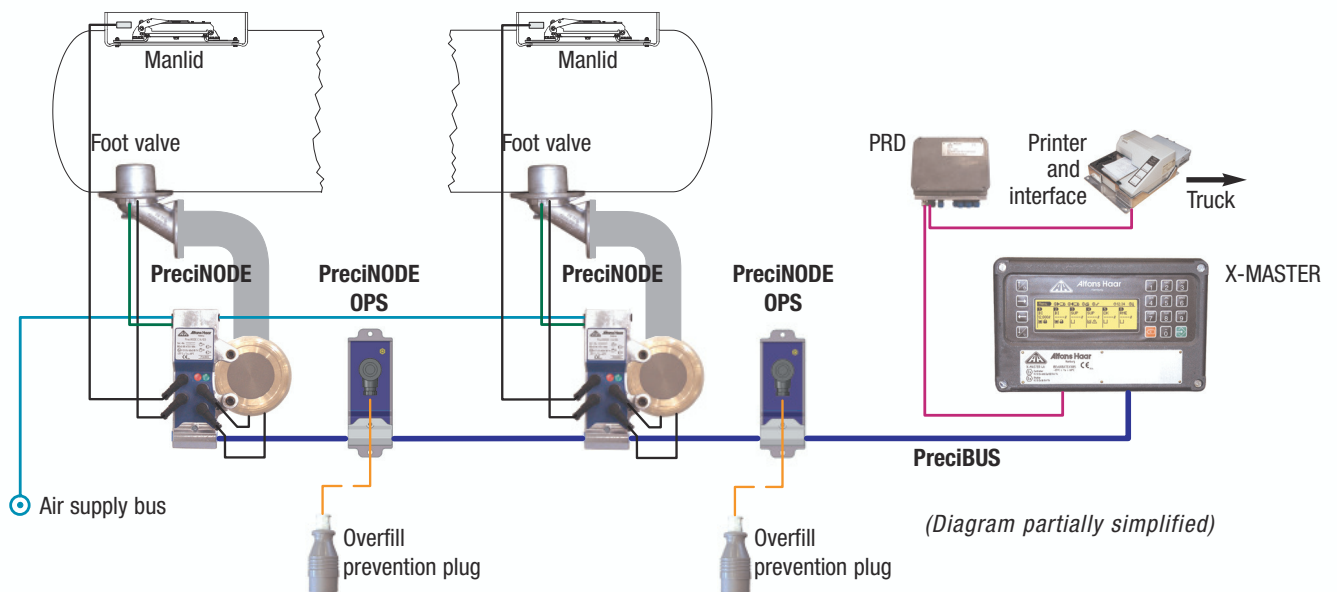

## No more boxes!

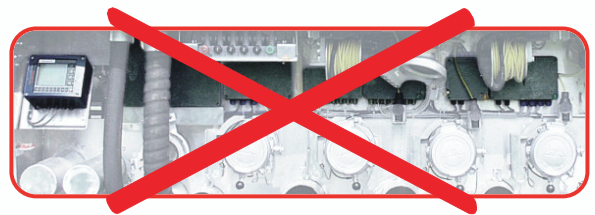

Alfons Haar now implements  
state of the art bus technology  
also in tank truck construction

### ADVANTAGES

- Cost and weight reduction due to reduced number of components and very light weight devices
- Reduced installation, improved transparency and simplification of maintenance, no terminal boxes, plug-in wiring
- Simple and safe configuration of the complete system on PC
- Safe operation by menu-based navigation, status indicators on API couplings and remote display
- Manipulation safe by integrated sensors, sealed interfaces and power fail safe buffer battery operation (battery lifetime up to 5 years)
- Future-proof by full compliance with international standards and unrestricted upgrading

# PreciCONTROL

Application: COP, SPDS, DTMQ, MID, FTL



**Alfons Haar**

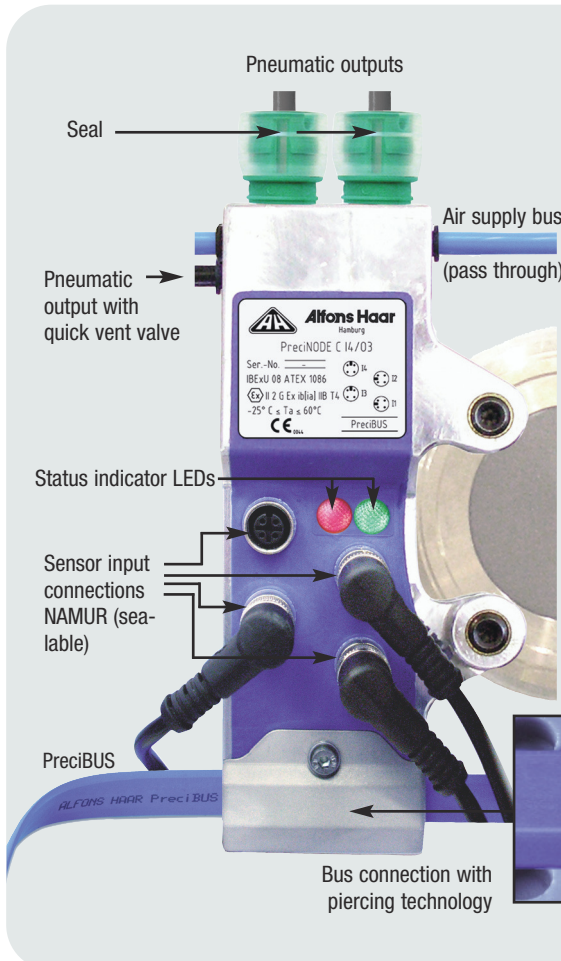

## PreciNODE C 14/03

The sensor/actor module PreciNODE monitors and controls the fittings on the truck:

- Fits on every standard flange, no drilling, no tapping (fast and safe)
- Reduced pneumatic installation by integrated solenoid valves
- 90% less power consumption conserves truck battery especially in winter
- NAMUR inputs, potted electronics, manipulation-safe

## TECHNICAL DATA

Temperature: -25°C to 60°C (-13F to 140F)  
 Dimensions: WxHxD 82x198x33mm  
 Protection class: >IP 67  
 4 NAMUR inputs  
 3 solenoid valve outputs

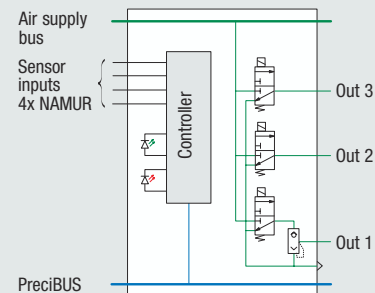

## PreciBUS

The AH PreciBUS offers among others the following advantages:

- In-line connections and piercing technology result in minimum wiring effort, no terminal boxes, no bolting
- The PreciBUS members can be contacted at any position of the bus cable
- Special AH bus cables prevent from reverse polarity
- Power and communication within one cable
- Easily extendable, any bus topology is possible

Data connections in the tractor based on established standards: FTL, FMS truck-interface via CAN BUS

